

CUSTOMER NAME   
 PHONE NUMBER

Address

Signature

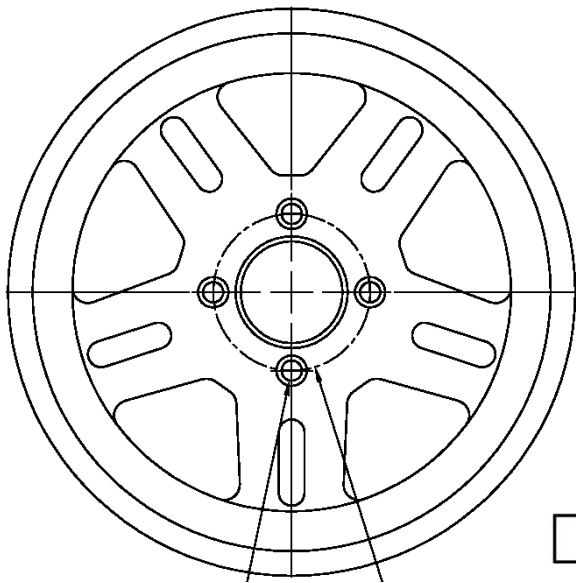

**C°SINK ANGLE**  
 Eg. 60° Std.  
 Optional (45°)

**BOLT CIRCLE DIA.**  
 Eg. 4 X 100mm  
 4 X 4.5  
 5 X 4.5  
 4 X 3.75

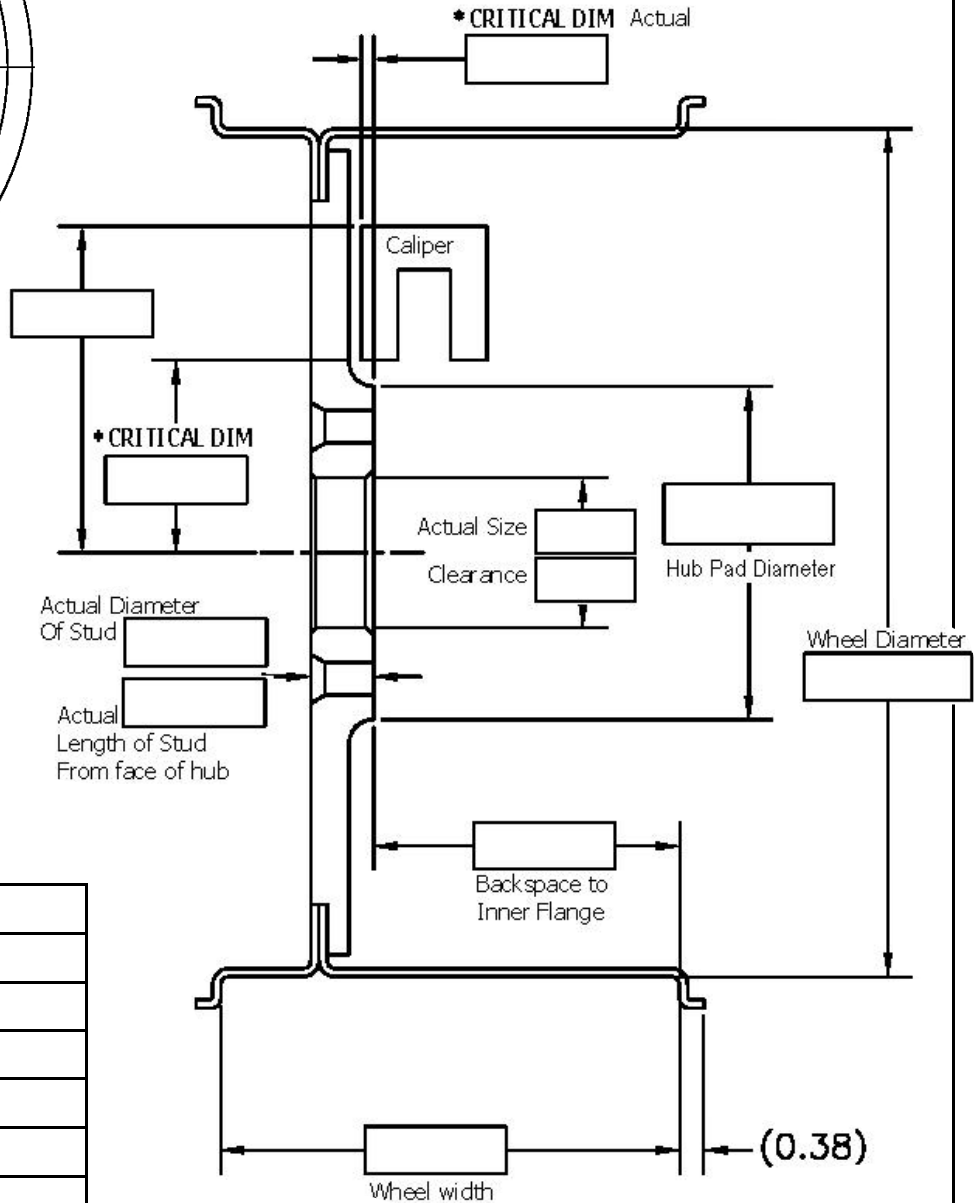

CAR TYPE	<input type="text"/>
CAR WEIGHT	<input type="text"/>
G-LOAD CAPACITY	<input type="text"/>

**FOR CENTER-LOCK WHEELS**

LENGTH OF STUB AXLE	<input type="text"/>
CENTER LOCK WASHER DIA.	<input type="text"/>
ACTUAL DRIVE PIN DIA.	<input type="text"/>
DRIVE PIN DEPTH	<input type="text"/>
DRIVE PIN BOLT CIRCLE	<input type="text"/>
DRIVE PIN QTY.	<input type="text"/>
THICKNESS OF CENTER-LOCK WASHER	<input type="text"/>

**FOR ALL WHEELS**

WHEEL CENTER FINISH	POLISHED	BLACK	GOLD
WHEEL RIMS FINISH	POLISHED		
Standard wheel CENTER & RIM finish is POLISHED. Available CENTER colors: BLACK, RED, GOLD, ETC.			

FRONT  
 QTY

REAR  
 QTY

***Kodiak Motorsports***

Phone: (877) 856-7311 Fax: (604) 850-2078

CUSTOM WHEEL SPECIFICATION

INTERNAL USE ONLY		WORKORDER #
INNER RIM	SIZE:	THICKNESS:
OUTER RIM	SIZE:	THICKNESS:
WHEEL CENTER PROGRAMS		
FRONT	SIDE 1	SIDE 2
REAR	SIDE 1	SIDE 2